



J. HERNANDO

Calle Iplacea nº 6 – Polígono Ind. Las Matillas
28803 Alcalá de Henares (Madrid)
Tlf. 91 879 62 86
Fax. 91 879 78 70

info@jhernando.com

• **Rodillos pesados tipo minería.**

TRAMO





J. HERNANDO

• Rodillos pesados tipo minería.

TRAMO

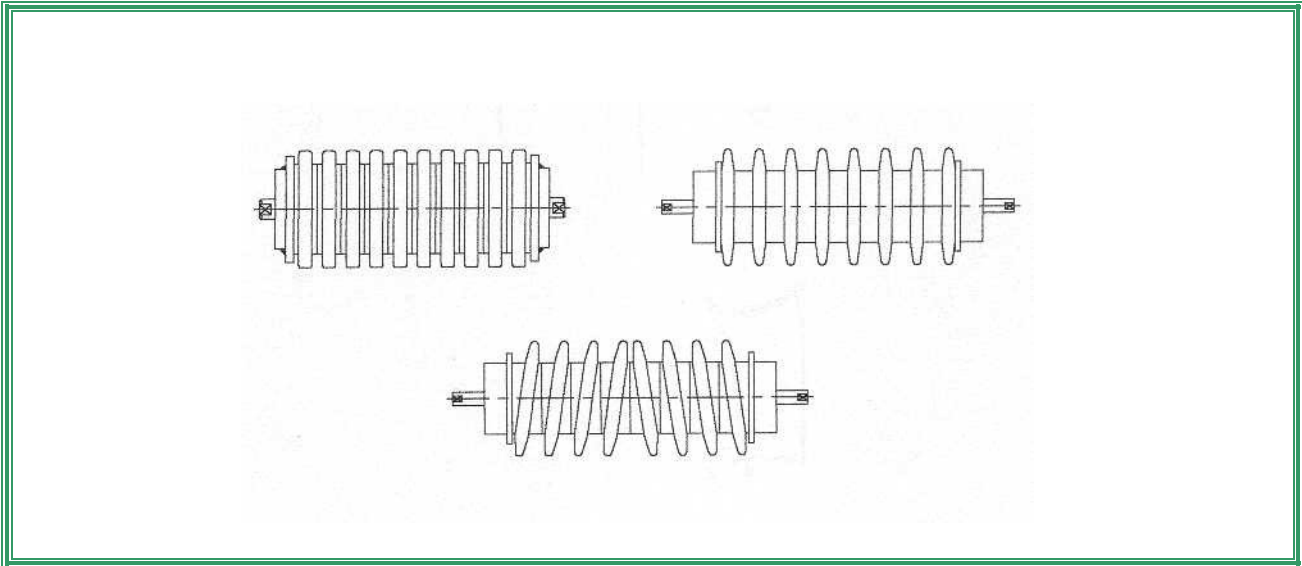
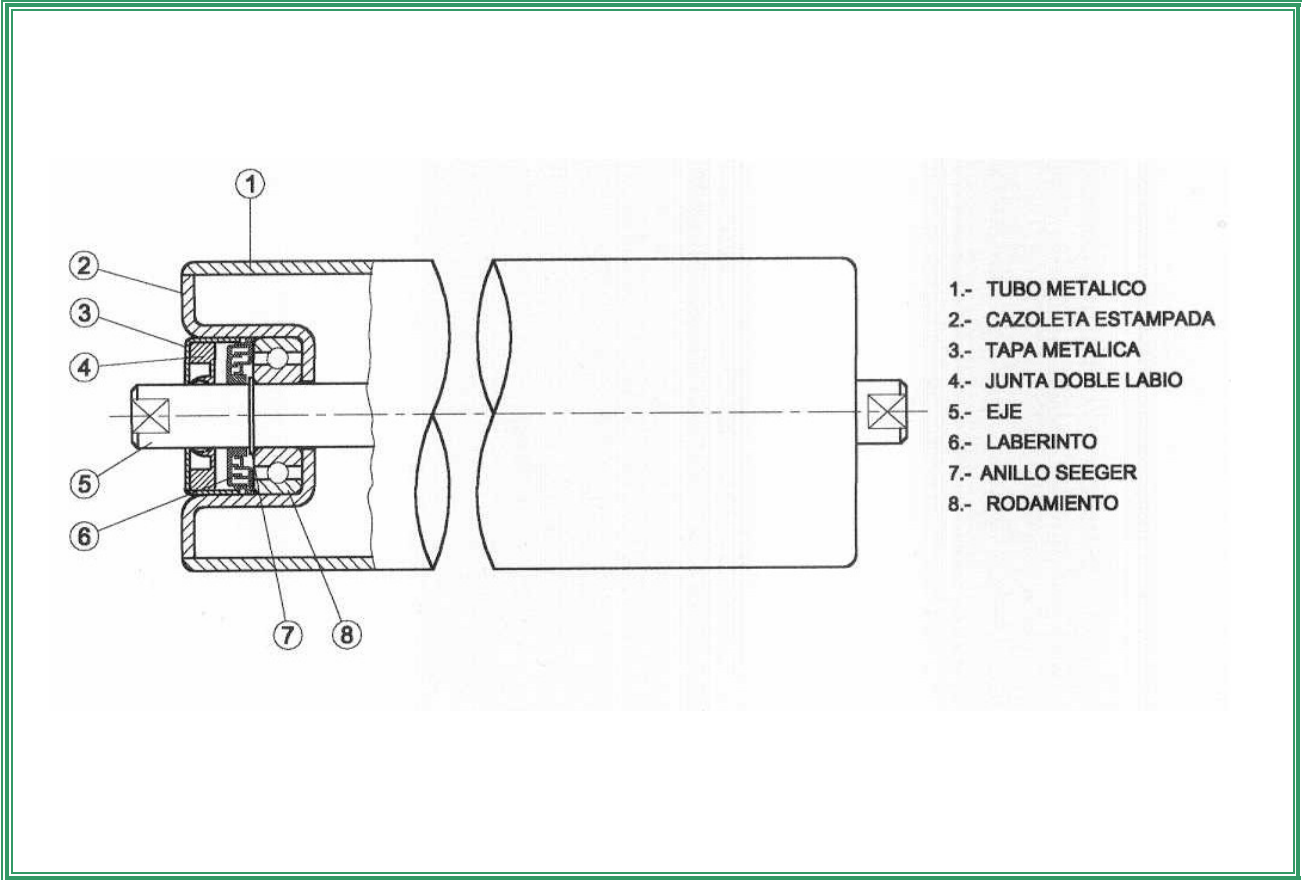



J. HERNANDO

Rodillos pesados tipo minería.

TRAMO

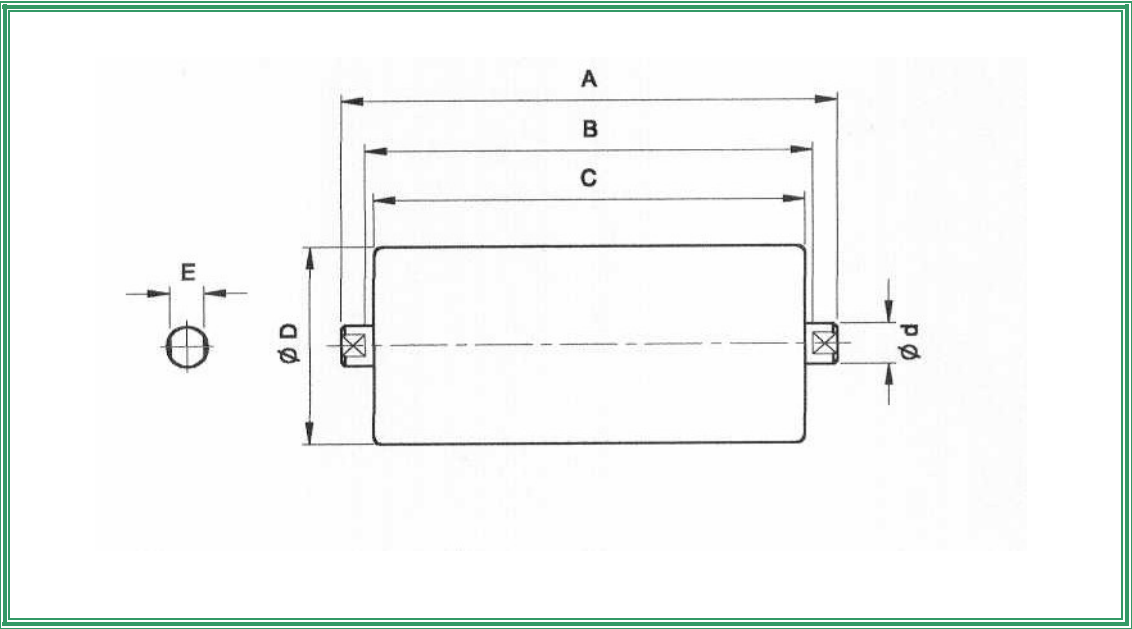

RODILLOS SUPERIORES - NORMA UNE

Ancho Banda	400	500	600	650	800	Ancho Banda	400	500	600	650	800	Ancho Banda	400	500	600	650	800
ϕD	$\phi 60$					ϕD	$\phi 70$					ϕD	$\phi 89$				
ϕd	$\phi 17 - \phi 20$					ϕd	$\phi 20 - \phi 25$					ϕd	$\phi 20 - \phi 25 - \phi 30$				
E	12 14					E	14 18					E	14 18 22				
C	150	190	225	240	290	C	150	190	225	240	290	C	150	190	225	240	290
B	156	196	231	246	296	B	156	196	231	246	296	B	156	196	231	246	296
A	176	216	251	266	316	A	176	216	251	266	316	A	176	216	251	266	316
Rodamiento	6203 - 6204					Rodamiento	6204 - 6205					Rodamiento	6204 - 6205 - 6206				

Ancho Banda	1.000	1.200	1.400	1.600
ϕD	$\phi 108$			
ϕd	$\phi 20 - \phi 25 - \phi 30$			
E	14 18 22			
C	360	430	500	570
B	366	436	506	576
A	386	456	526	596
Rodamiento	6204 - 6205 - 6206			

Ancho Banda	1.000	1.200	1.400	1.600
ϕD	$\phi 133$			
ϕd	$\phi 20 - \phi 25 - \phi 30$			
E	14 18 22			
C	360	430	500	570
B	366	436	506	576
A	386	456	526	596
Rodamiento	6204 - 6205 - 6206			

Ancho Banda	1.000	1.200	1.400	1.600
ϕD	$\phi 159$			
ϕd	$\phi 25 - \phi 30$			
E	18 22			
C	360	430	500	570
B	366	436	506	576
A	386	456	526	596
Rodamiento	6205 - 6206			



J. HERNANDO

Rodillos pesados tipo minería.

TRAMO

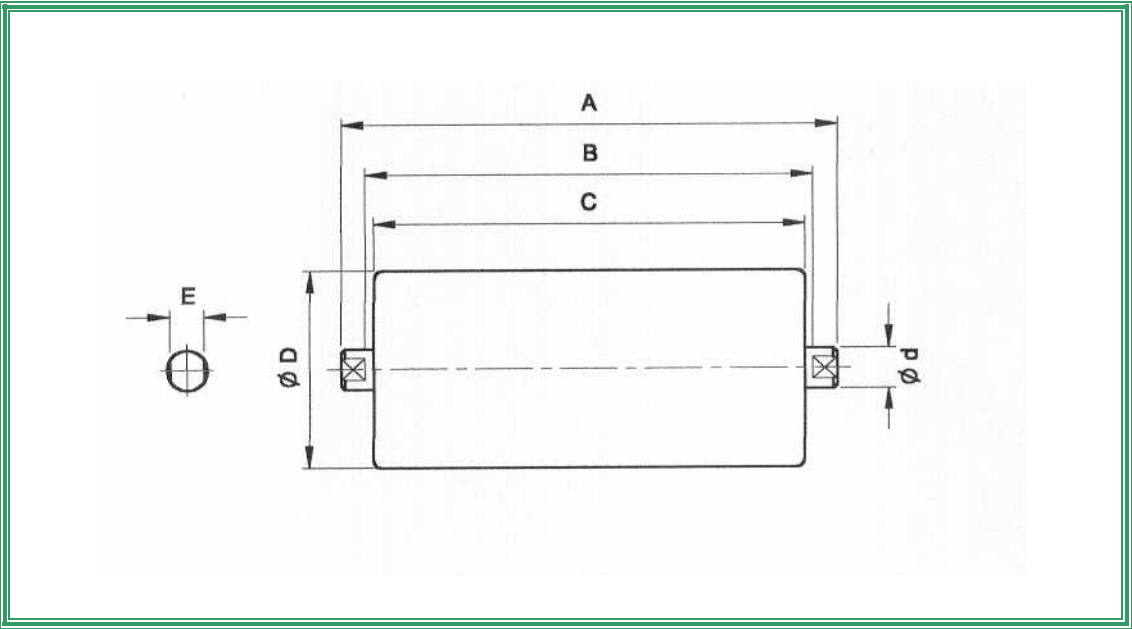

RODILLOS INFERIORES - NORMA UNE																	
Ancho Banda	400	500	600	650	800	Ancho Banda	400	500	600	650	800	Ancho Banda	400	500	600	650	800
ϕD	$\phi 60$					ϕD	$\phi 70$					ϕD	$\phi 89$				
ϕd	$\phi 17 - \phi 20$					ϕd	$\phi 20 - \phi 25$					ϕd	$\phi 20 - \phi 25 - \phi 30$				
E	12 14					E	14 18					E	14 18 22				
C	475	575	675	725	875	C	475	575	675	725	875	C	475	575	675	725	875
B	508	608	708	758	908	B	508	608	708	758	908	B	508	608	708	758	908
A	540	640	740	790	940	A	540	640	740	790	940	A	540	640	740	790	940
Rodamiento	6203 - 6204					Rodamiento	6204 - 6205					Rodamiento	6204 - 6205 - 6206				

Ancho Banda	1.000	1.200	1.400	1.600	Ancho Banda	1.000	1.200	1.400	1.600	Ancho Banda	1.000	1.200	1.400	1.600
ϕD	$\phi 108$				ϕD	$\phi 133$				ϕD	$\phi 159$			
ϕd	$\phi 20 - \phi 25 - \phi 30$				ϕd	$\phi 20 - \phi 25 - \phi 30$				ϕd	$\phi 25 - \phi 30$			
E	14 18 22				E	14 18 22				E	18 22			
C	1.115	1.315	1.515	1.715	C	1.115	1.315	1.515	1.715	C	1.115	1.315	1.515	1.715
B	1.148	1.348	1.548	1.748	B	1.148	1.348	1.548	1.748	B	1.148	1.348	1.548	1.748
A	1.180	1.380	1.580	1.780	A	1.180	1.380	1.580	1.780	A	1.180	1.380	1.580	1.780
Rodamiento	6204 - 6205 - 6206				Rodamiento	6204 - 6205 - 6206				Rodamiento	6205 - 6206			



J. HERNANDO

Rodillos pesados tipo minería.

TRAMO

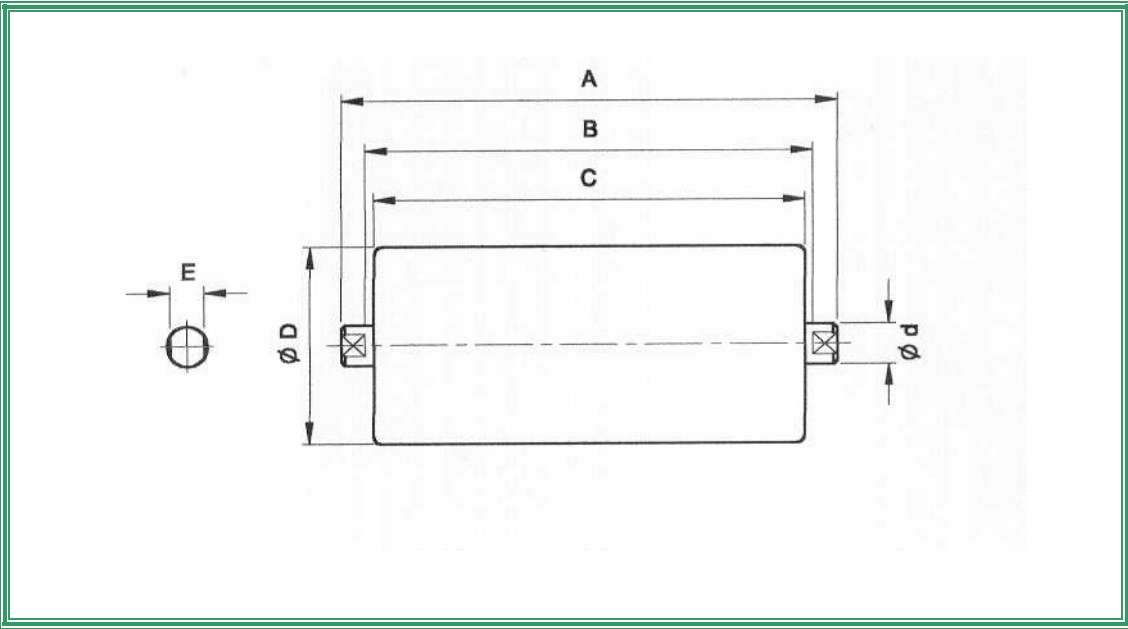

RODILLOS SUPERIORES - NORMA FEM																	
Ancho Banda	400	500	---	650	800	Ancho Banda	400	500	---	650	800	Ancho Banda	400	500	---	650	800
ϕD	$\phi 60$					ϕD	$\phi 70$					ϕD	$\phi 89$				
ϕd	$\phi 17 - \phi 20$					ϕd	$\phi 20 - \phi 25$					ϕd	$\phi 20 - \phi 25 - \phi 30$				
E	12 14					E	14 18					E	14 18 22				
C	165	200	---	250	315	C	165	200	---	250	315	C	165	200	---	250	315
B	173	208	---	258	323	B	173	208	---	258	323	B	173	208	---	258	323
A	191	226	---	276	341	A	191	226	---	276	341	A	191	226	---	276	341
Rodamiento	6203 - 6204					Rodamiento	6204 - 6205					Rodamiento	6204 - 6205 - 6206				

Ancho Banda	1.000	1.200	1.400	1.600
ϕD	$\phi 108$			
ϕd	$\phi 20 - \phi 25 - \phi 30$			
E	14 18 22			
C	380	465	530	600
B	388	473	538	608
A	406	491	556	626
Rodamiento	6204 - 6205 - 6206			

Ancho Banda	1.000	1.200	1.400	1.600
ϕD	$\phi 133$			
ϕd	$\phi 20 - \phi 25 - \phi 30$			
E	14 18 22			
C	380	465	530	600
B	388	473	538	608
A	406	491	556	626
Rodamiento	6204 - 6205 - 6206			

Ancho Banda	1.000	1.200	1.400	1.600
ϕD	$\phi 159$			
ϕd	$\phi 25 - \phi 30$			
E	18 22			
C	380	465	530	600
B	388	473	538	608
A	406	491	556	626
Rodamiento	6205 - 6206			



J. HERNANDO

Rodillos pesados tipo minería.

TRAMO

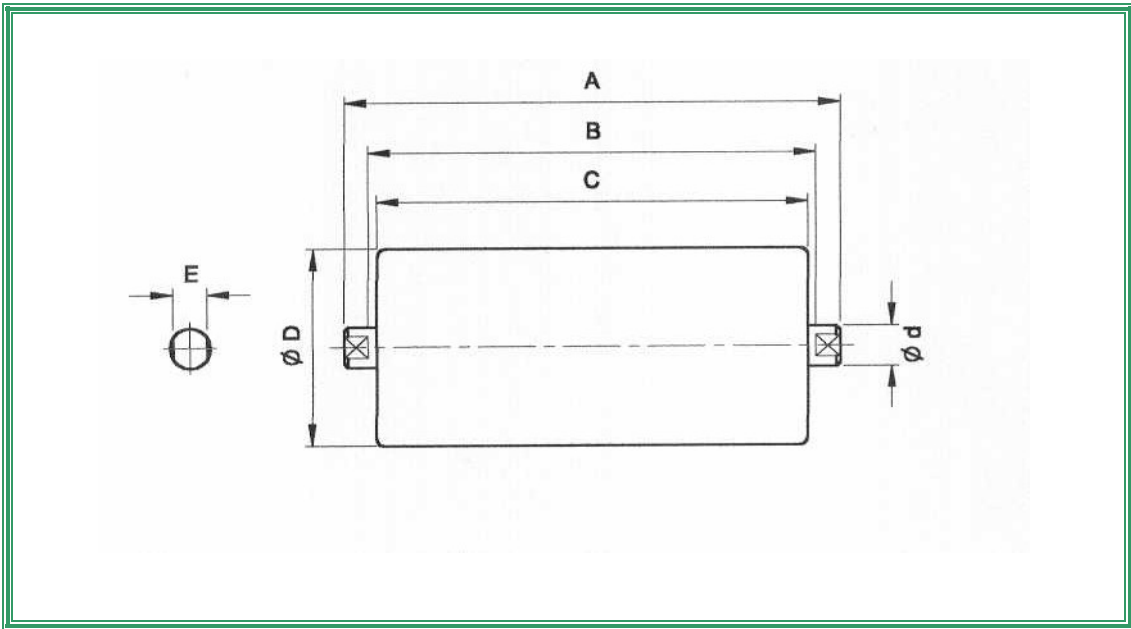

RODILLOS INFERIORES - NORMA FEM

Ancho Banda	400	500	---	650	800	Ancho Banda	400	500	---	650	800	Ancho Banda	400	500	---	650	800
ϕD	$\phi 60$					ϕD	$\phi 70$					ϕD	$\phi 89$				
ϕd	$\phi 17 - \phi 20$					ϕd	$\phi 20 - \phi 25$					ϕd	$\phi 20 - \phi 25 - \phi 30$				
E	12 14					E	14 18					E	14 18 22				
C	500	600	---	750	950	C	500	600	---	750	950	C	500	600	---	750	950
B	508	608	---	758	958	B	508	608	---	758	958	B	508	608	---	758	958
A	546	646	---	796	996	A	546	646	---	796	996	A	546	646	---	796	996
Rodamiento	6203 - 6204					Rodamiento	6204 - 6205					Rodamiento	6204 - 6205 - 6206				

Ancho Banda	1.000	1.200	1.400	1.600
ϕD	$\phi 108$			
ϕd	$\phi 20 - \phi 25 - \phi 30$			
E	14 18 22			
C	1.150	1.400	1.600	1.800
B	1.158	1.408	1.608	1.808
A	1.196	1.446	1.646	1.846
Rodamiento	6204 - 6205 - 6206			

Ancho Banda	1.000	1.200	1.400	1.600
ϕD	$\phi 133$			
ϕd	$\phi 20 - \phi 25 - \phi 30$			
E	14 18 22			
C	1.150	1.400	1.600	1.800
B	1.158	1.408	1.608	1.808
A	1.196	1.446	1.646	1.846
Rodamiento	6204 - 6205 - 6206			

Ancho Banda	1.000	1.200	1.400	1.600
ϕD	$\phi 159$			
ϕd	$\phi 25 - \phi 30$			
E	18 22			
C	1.150	1.400	1.600	1.800
B	1.158	1.408	1.608	1.808
A	1.196	1.446	1.646	1.846
Rodamiento	6205 - 6206			



J. HERNANDO

● Rodillos ligeros ϕ 20 mm.

TRAMO

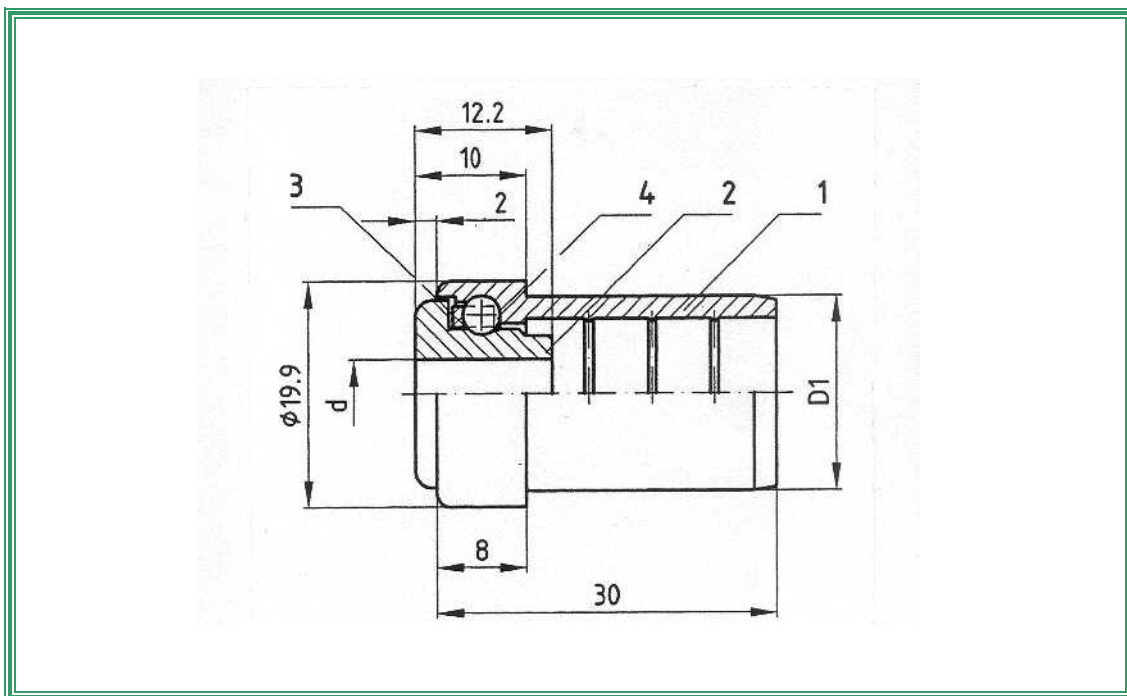

ϕ Rodillo	Pared	ϕ eje (d+0,2)	D1+0,15	Carga (daN)
20	1,5	6	17,1	5
20	1,5	8	17,1	5



J. HERNANDO

● Rodillos ligeros de ϕ 30 y ϕ 40 mm.

TRAMO

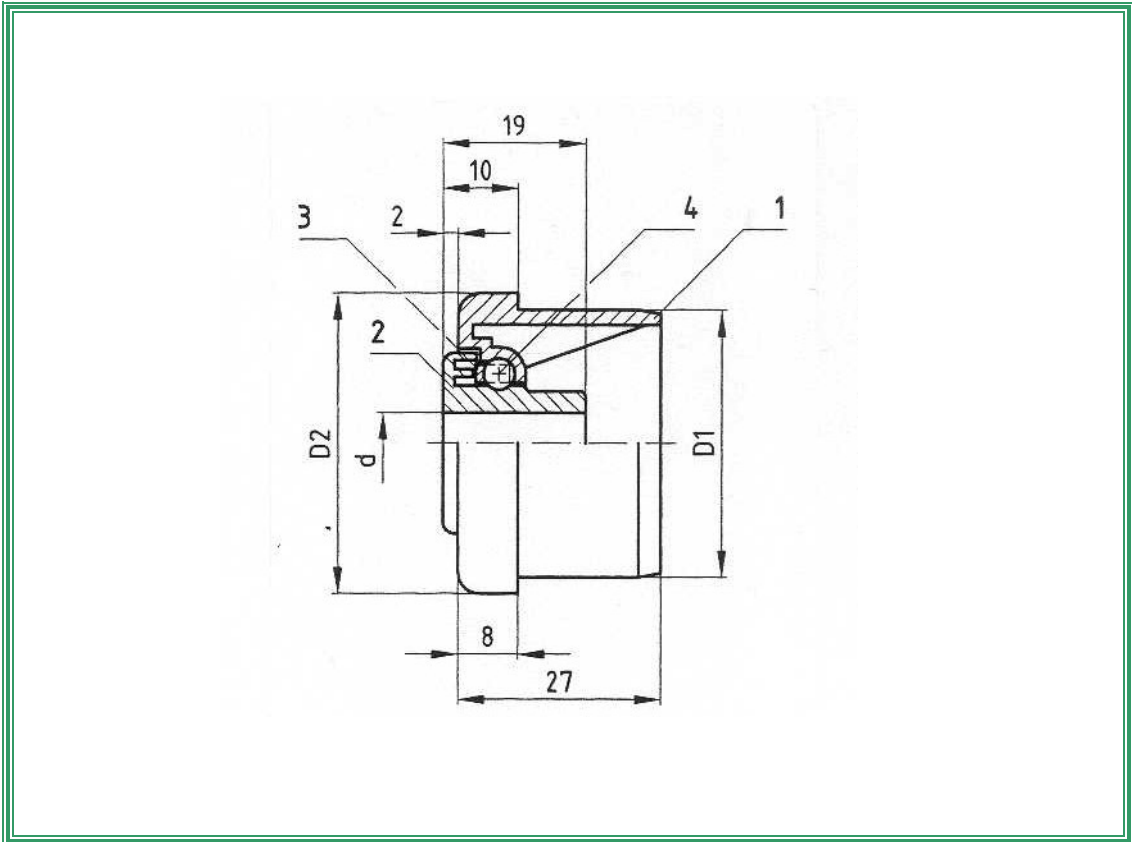

ϕ Rodillo	Pared	ϕ eje	$D1+0,25$	$D2-0,2$	Carga (daN)
30	1	8	28,1	29,9	7
30	1	10	28,1	29,9	7
40	1,5	8	37,1	39,9	7
40	1,5	10	37,1	39,9	7



J. HERNANDO

• Rodillos ligeros de ϕ 50 y ϕ 60 mm.

TRAMO

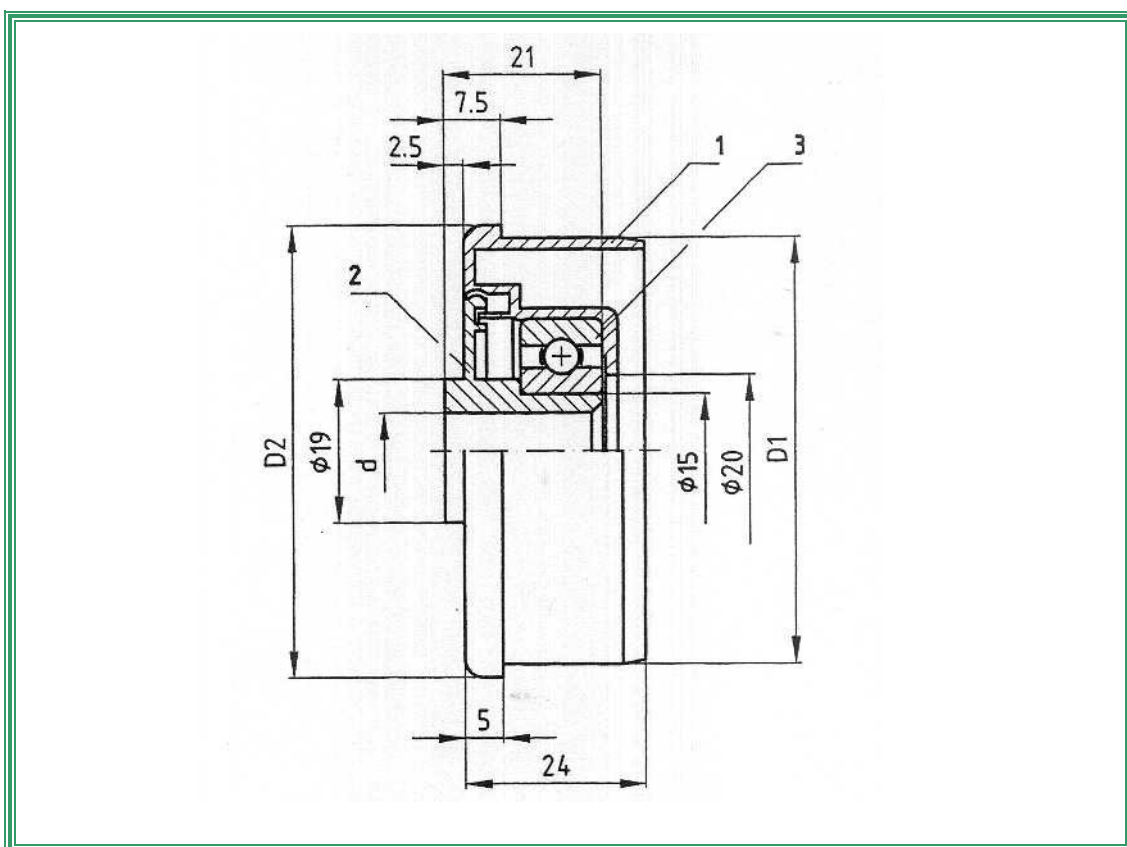

ϕ Rodillo	Pared	ϕ eje	D1+0,2	D2-0,2	Carga (daN)
50	1,5	10	47,3	49,9	80
50	1,5	12	47,3	49,9	80
50	1,5	14	47,3	49,9	80
50	1,5	hexagonal 11	47,3	49,9	80
60	2	10	56,3	59,9	80
60	2	12	56,3	59,9	80
60	2	14	56,3	59,9	80
60	2	hexagonal 11	56,3	59,9	80



J. HERNANDO

• Rodillos de ϕ 50 mm, con piñón doble.

TRAMO

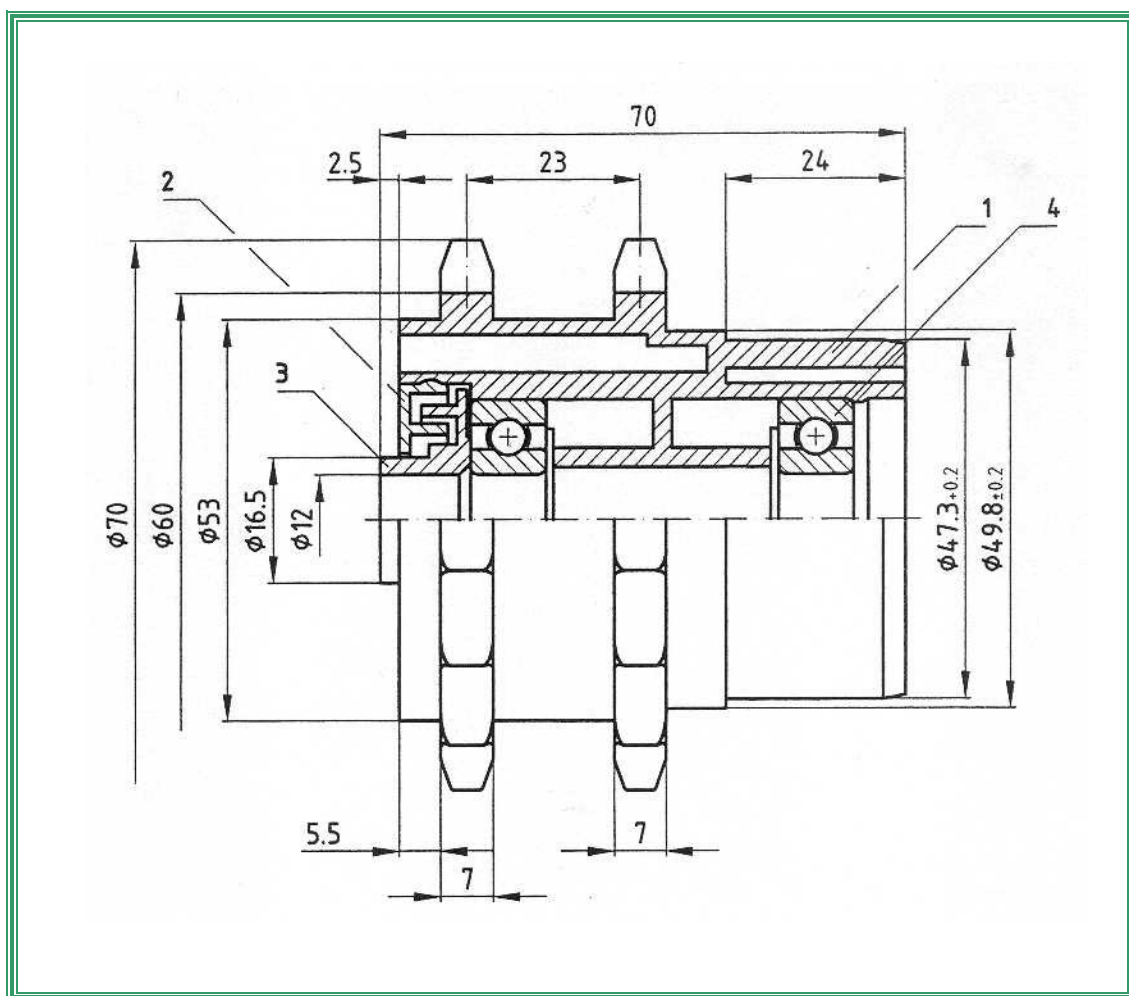

ϕ Rodillo	Pared	ϕ eje	Piñones	Rodamiento
50	1,5	12	1/2"	6201



J. HERNANDO

• Rodillos de ϕ 50 mm, con piñón simple (fricción).

TRAMO

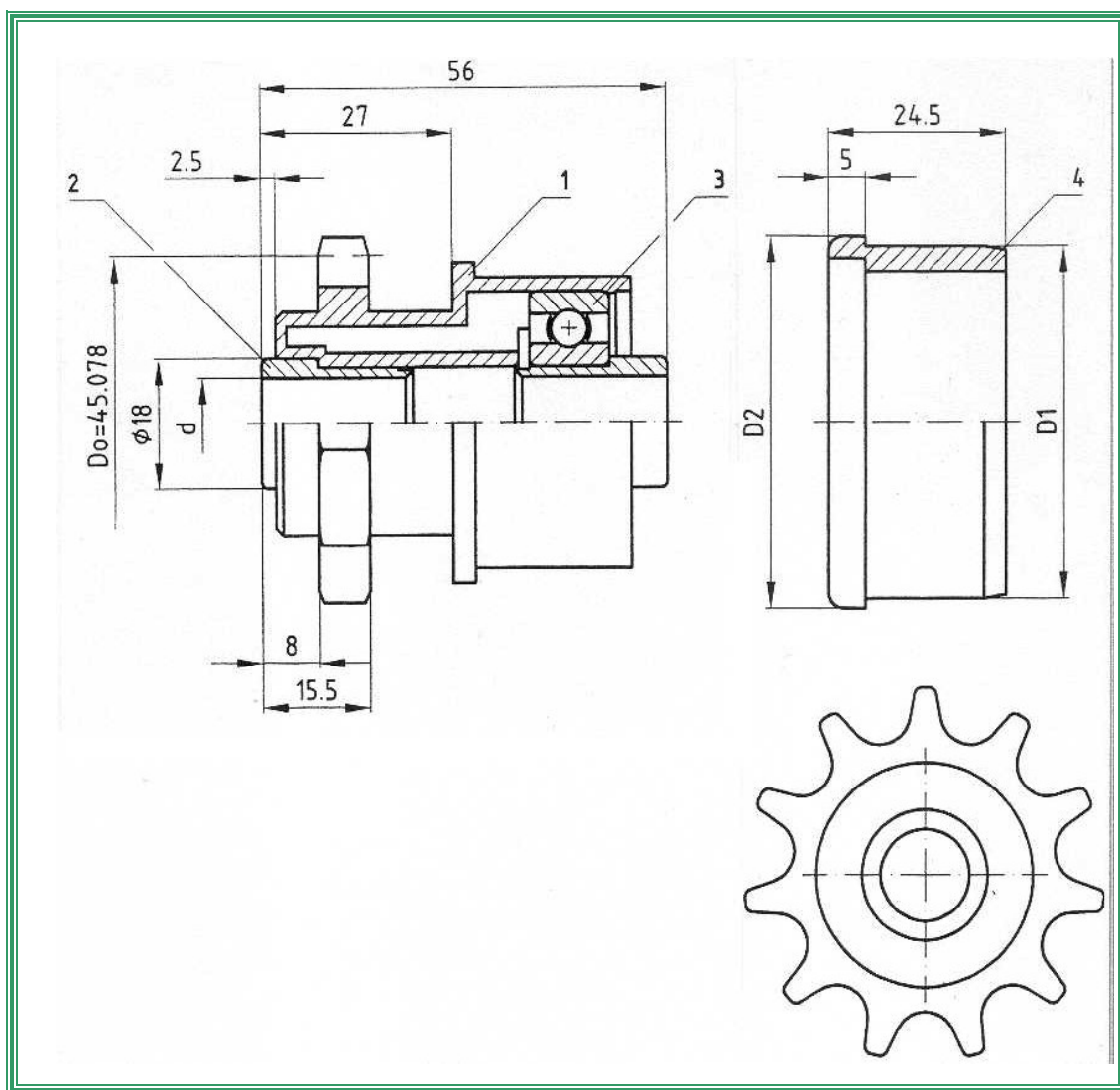

ϕ Rodillo	Pared	ϕ eje	D1+0,2	D2-0,2	Piñones	Fricción
50	1,5	12	47,3	49,9	1/2"	SI



J. HERNANDO

• Rodillos de ϕ 50 mm, con piñón simple.

TRAMO

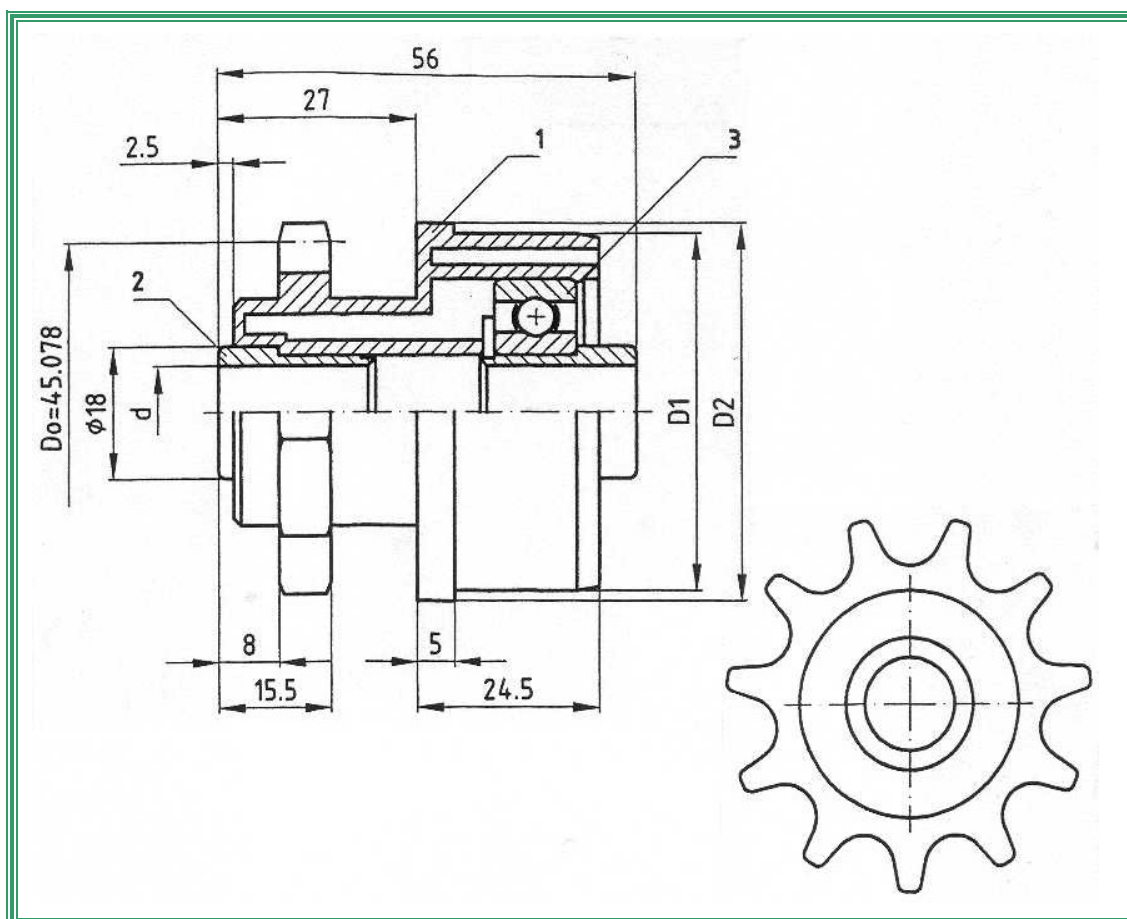

ϕ Rodillo	Pared	ϕ eje	D1+0,2	D2-0,2	Piñones	Fricción
50	1,5	12	47,3	49,9	1/2"	NO



J. HERNANDO

● Rodillos ligeros de ϕ 30 mm.

TRAMO

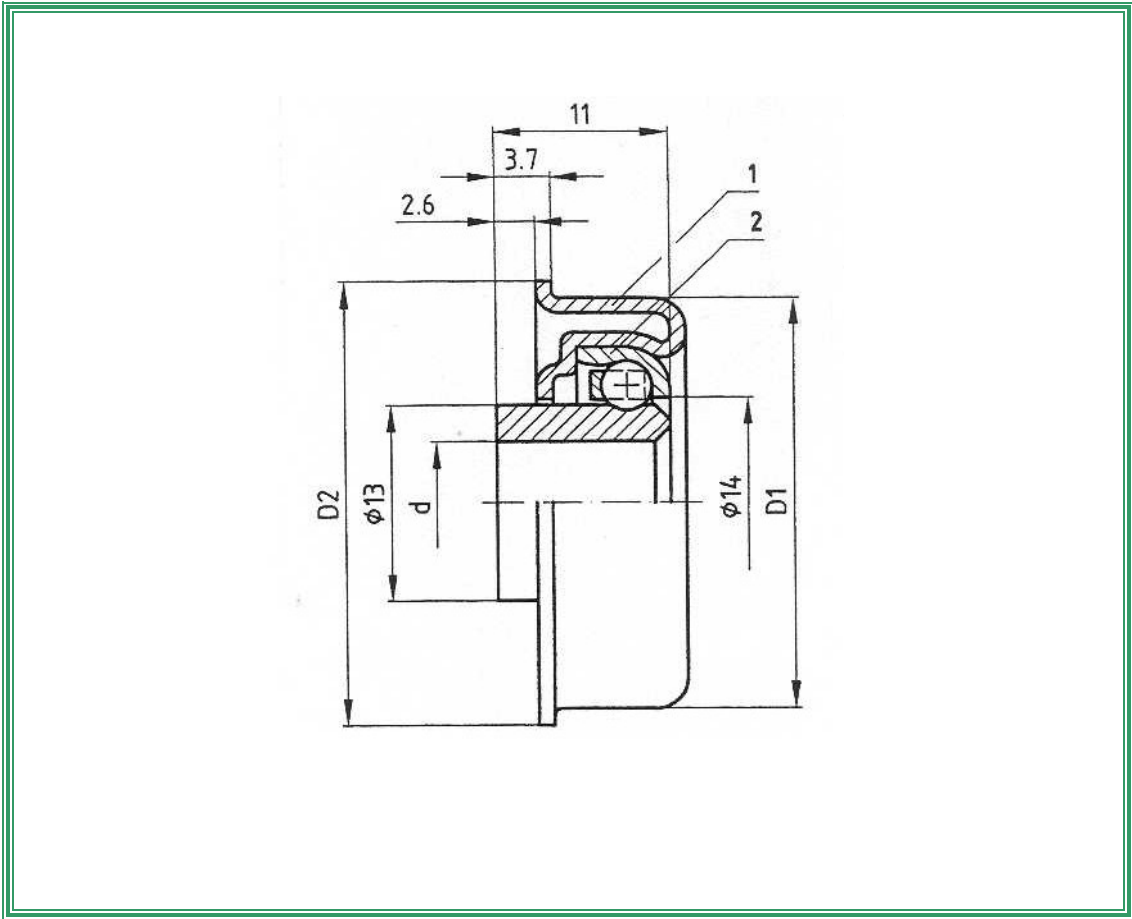

ϕ Rodillo	Pared	ϕ eje	D1+/-0,1	D2-/-0,2	Carga (daN)
30	1,5	8	27,3	29,6	30
30	1,5	10	27,3	29,6	30



J. HERNANDO

● Rodillos ligeros de ϕ 40, ϕ 50, ϕ 60 y ϕ 80 mm.

TRAMO

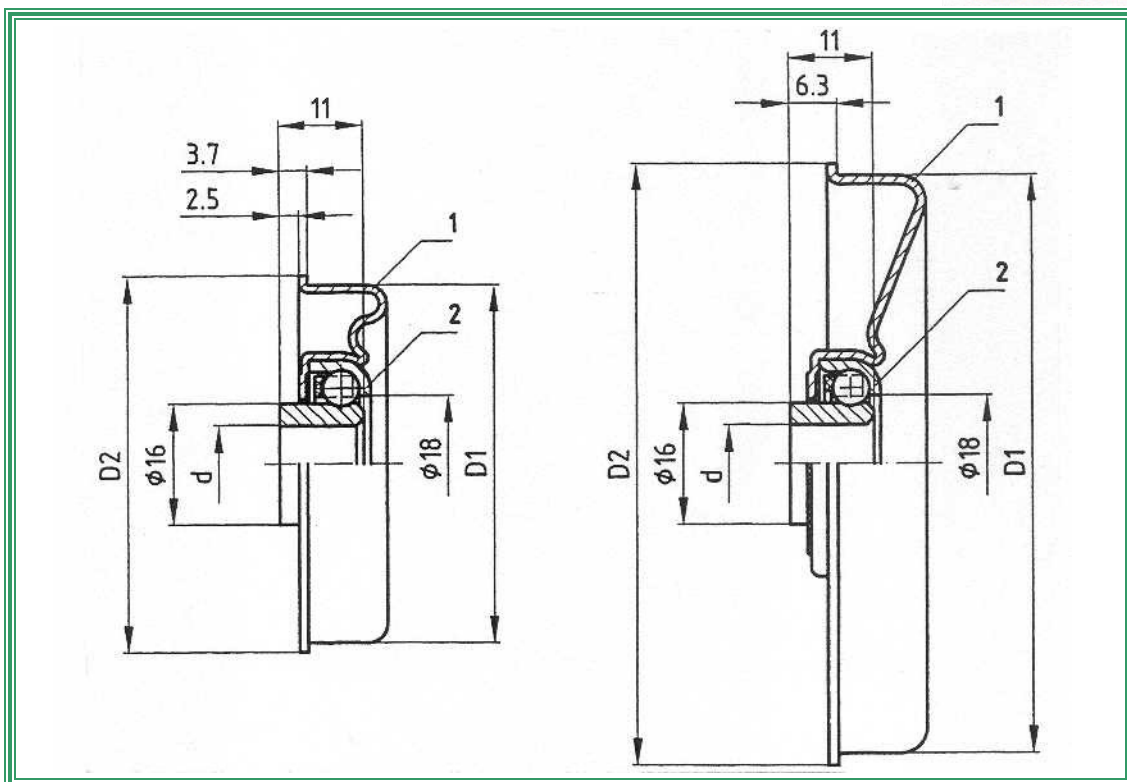

ϕ Rodillo	Pared	ϕ eje	D1+/-0,1	D2-/-0,2	Carga (daN)
40	1,5	8	37,3	39,5	80
40	1,5	10	37,3	39,5	80
40	1,5	12	37,3	39,5	80
40	1,5	Hexagonal 11	37,3	39,5	80
50	1,5	8	47,3	49,5	80
50	1,5	10	47,3	49,5	80
50	1,5	12	47,3	49,5	80
50	1,5	Hexagonal 11	47,3	49,5	80
60	2	8	56,3	59,5	80
60	2	10	56,3	59,5	80
60	2	12	56,3	59,5	80
60	2	Hexagonal 11	56,3	59,5	80
80	2	8	76,4	79,5	80
80	2	10	76,4	79,5	80
80	2	12	76,4	79,5	80
80	2	Hexagonal 11	76,4	79,5	80